

DEHUMIDIFIER

DH 720 P

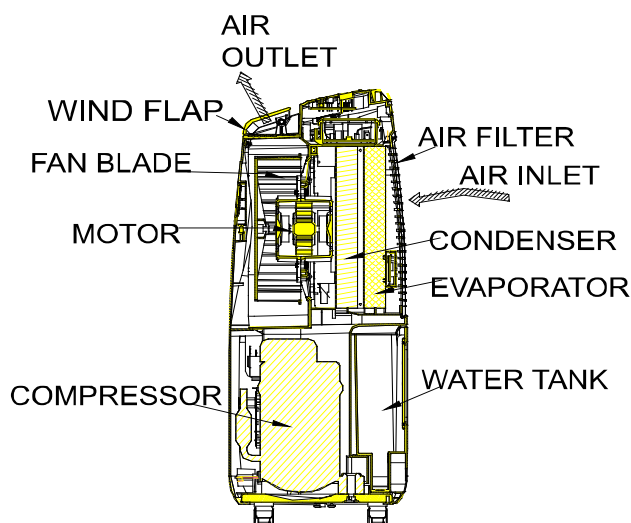

FUNCTIONING PRINCIPLES



The dehumidifier controls humidity by forcing the excess of moisture to condense from the air into the unit as it passes over the cooling elements. Contact with this cold surface causes the moisture in the air to condense. This condensed water drains safely into the water tank. The dried air then passes through a warmed coil where it is warmed and reenters the room at slightly higher temperature.

TECHNICAL DATA

Capacity (30°C/80%Rh)	l/24h	20	Refrigerant	R290
			Refrigerant mass.	kg
				0,09
Working range	°C / %RH	5-32 / 35-95	GWP	3
Net weight	kg	11	CO ₂ Eq	t
				0,0003
Gross weight	kg	12,6	Power supply	V
				220-240
Noise level	dB(A)	48	Frequency	Hz
				50
Air flow	m ³ /h	150	Rated current	A
				1,9
Tank capacity	l	5	Power consumption	W
				415

PACKING

Package dimensions	mm	385 x 260 x 610
Device dimensions	mm	340 x 210 x 570
Pieces per Euro-pallet	n°	27
Pallet dimensions	mm	800 x 1200 x 1980

COMPONENTS

Compressor	rotary
Fan	centrifugal
Water tank	5 l
Defrosting system	air flow
Hygostat	electronic
Wheels	plastic, four pieces, diameter 24mm
Room temperatur sensor	Power cord with angular plug (H05VV-F 3G0,75mm ²)
Evaparator temperatur sensor	Humidity level LED indicator
Temperatur control senseor	

DEHUMIDIFYING CURVE DIAGRAM

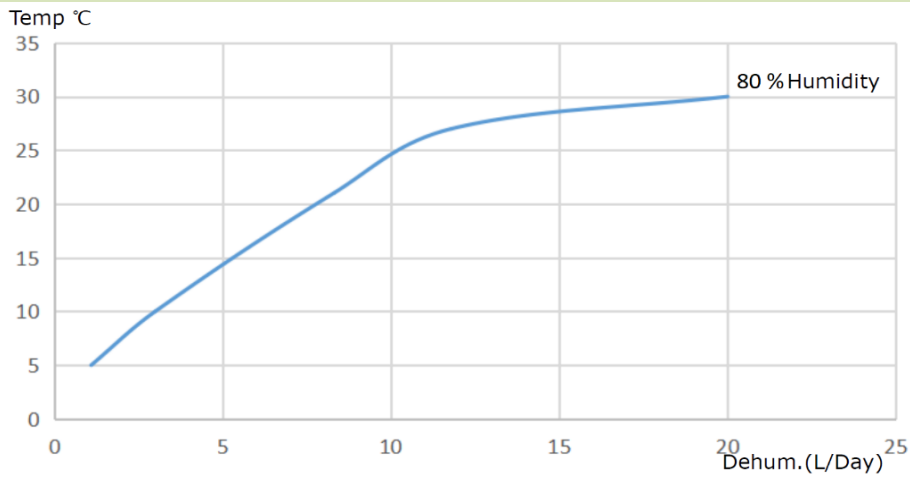

WIRING DIAGRAM

