

DEHUMIDIFIER

DHP 65

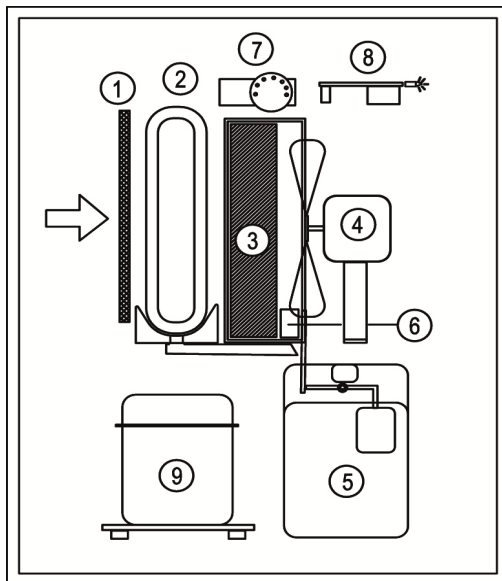

FUNCTIONING DIAGRAM



1	:	Filter
2	:	Evaporator
3	:	Condenser
4	:	Fan
5	:	Tank
6	:	Switch
7	:	Moisture gauge
8	:	Electronic board
9	:	Compressor

TECHNICAL DATA

Functioning Relative Humidity Range	%	38 - 99
Functioning Temperature Range	°C	3 - 35
Air Flow	m ³ /h	500
Rated Condensation Capacity (30°C UR 80%)	l/24h	56
Type of Refrigerant Gas	type	R410A
Quantity of Refrigerant Gas	g	440
Voltage Power Supply	V	220-240
Frequency Power Supply	Hz	50
Power Consumption (35°C UR 99%)	W	780
Absorbed Current (35°C UR 99%)	A	3,9
Sound Pressure Level (at 3 mts)	dBa	53
Capacity of Condensed Water Tank	l/24h	10,5
Weight	Kg	45

PACKAGING

Packaging dimensions	mm	730 x 580 x 840
Net dimensions	mm	570 x 530 x 700

ELECTRICAL DIAGRAM

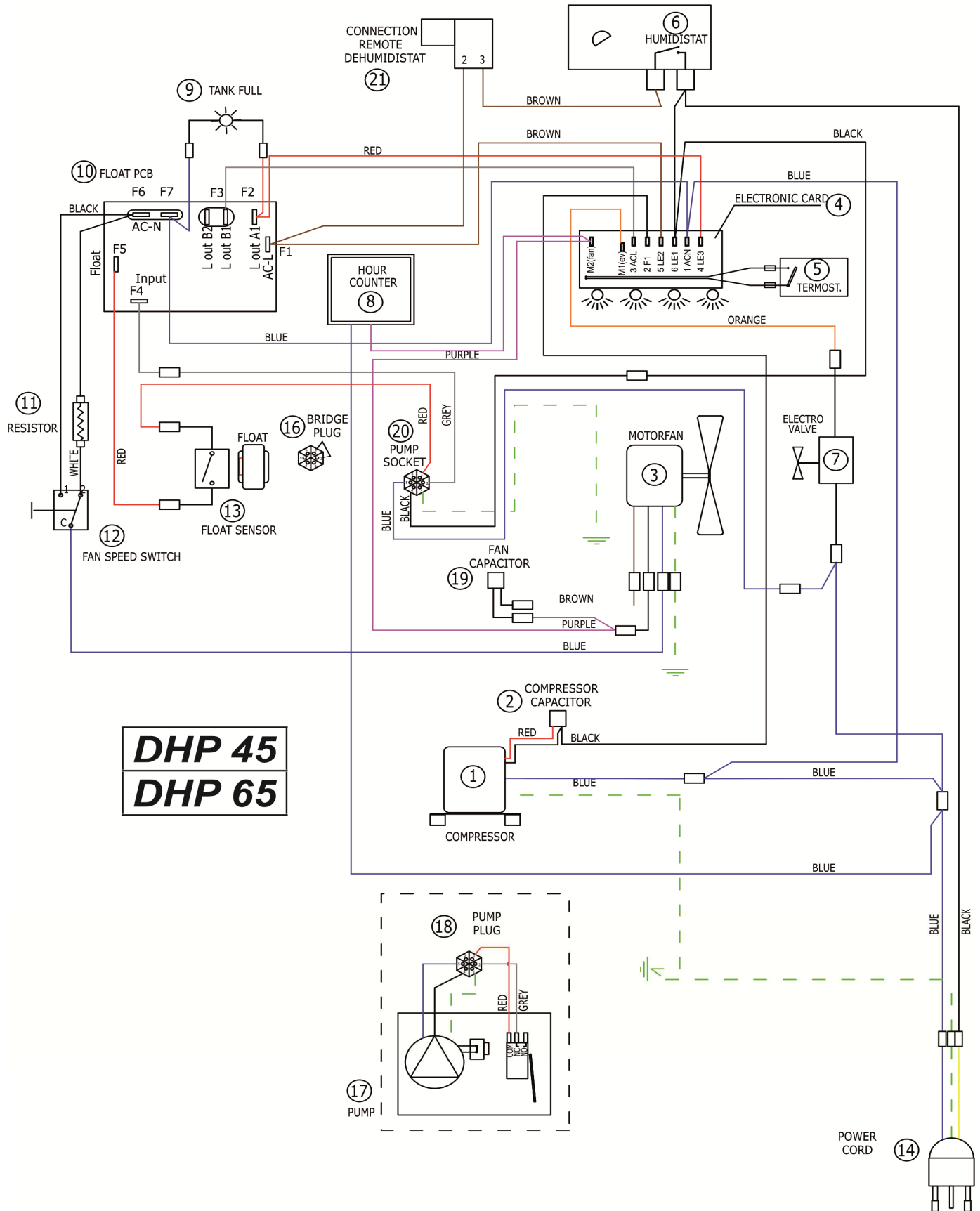

PERFORMANCE

